



Republic of the Philippines
GENERAL SANTOS CITY WATER DISTRICT
E. Fernandez Street, Barangay Lagao General Santos
Telephone No.: 552-3824; Telefax No.: 553-4960
Email Address: gscwdprocurement@yahoo.com

GPM-014-2

REQUEST FOR QUOTATION

RFQ #: 3-1119-017 DATE: 11/08/2019

SUPPLIER: _____
ADDRESS: _____
TELEPHONE NO. : _____
TIN NO. : _____

Dear Sir/Madam,

Pls. quote your lowest price on the item/s listed below subject to general condition stating the shortest time of delivery and submit your quotation duly signed by your representative not later than 11/14/2019, Pls. furnish this office the following articles subject to the terms and conditions contained therein.

ITEM NO.	DESCRIPTION	QTY.	UNIT	UNIT PRICE
1	STEEL FLANGE 150MM : PLEASE SEE ATTACHED SHOP DRAWING-ABC: PHP 60,000.00	20	pcs.	P
2	STEEL FLANGE 250MM : PLEASE SEE ATTACHED SHOP DRAWING-ABC: PHP 80,000.00 ##### nothing follows #####	20	pcs.	P

Date of Delivery: _____
Price Validity : _____
Terms of Payment: _____

Place of Delivery: GSCWD Bodega

****No partial delivery allowed****

Note: 6% WITHHOLDING TAX DEDUCTION

PR NO.: 1119-013

Requested by:

Price quoted by:

Gerson D. CABAÑERO
MATERIAL PROCUREMENT
OFFICER A

Supplier

Date

8 x Ø22mm EQUALLY SPACE ON A Ø240mm BC

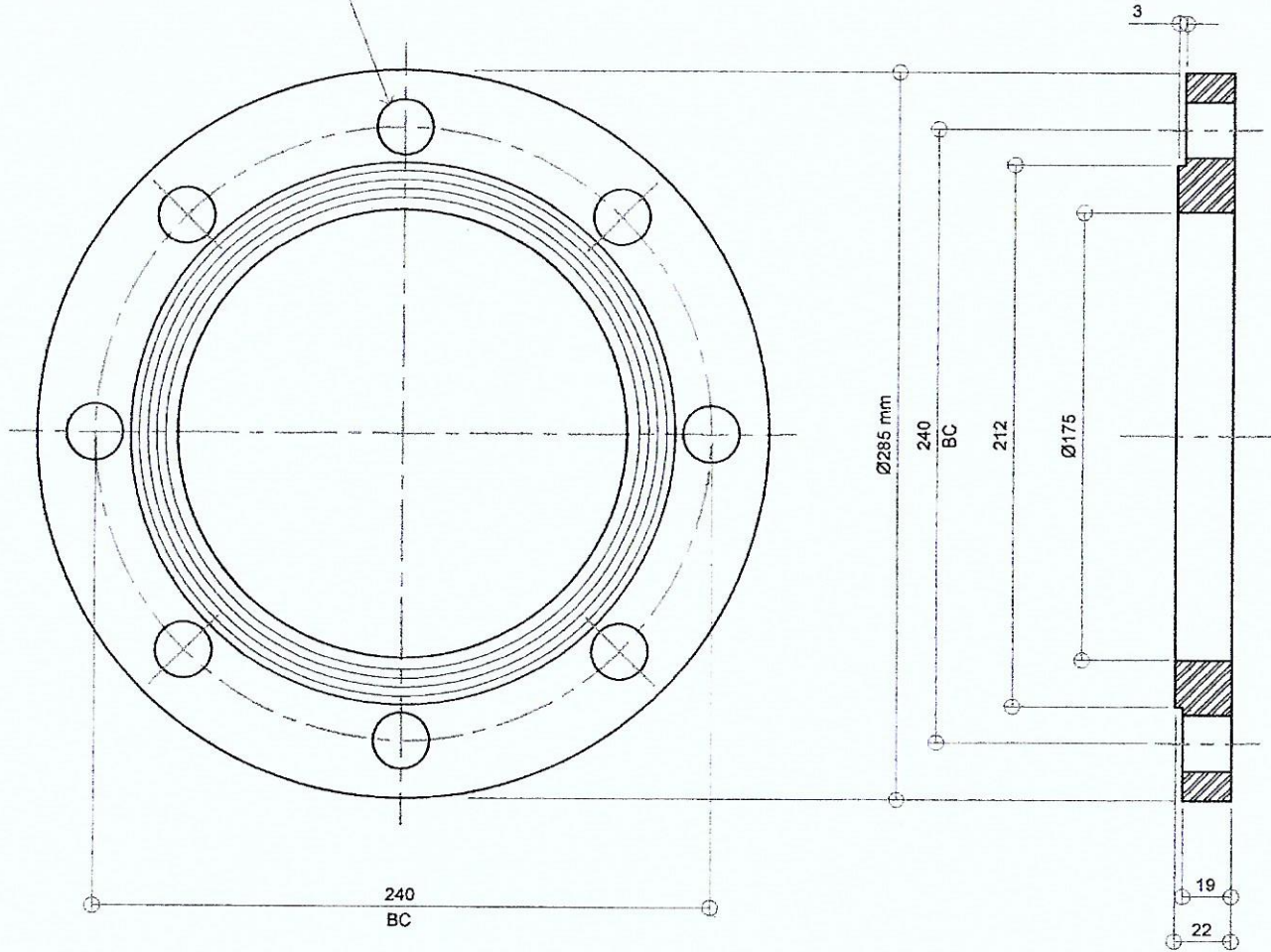

PLAN

SECTION

GENERAL SANTOS CITY WATER DISTRICT
 ENGINEERING & CONSTRUCTION DEPARTMENT
 PLANNING AND DESIGN DIVISION
 E. FERNANDEZ STREET, BRGY. LAGAO, GEN. SANTOS CITY
 TEL. NO.: (083) 652 - 3824

DESCRIPTION: SHOP DRAWING OF 150mm(6")Ø REVISED STEEL FLANGE	CHECKED BY: <i>[Signature]</i> ENGR. MICHAEL G. GABALES MANAGER - PDD	REVIEWED BY: <i>[Signature]</i> ENGR. ROGELIO A. BESANA, JR. MANAGER A - ECD	APPROVED BY: <i>[Signature]</i> ENGR. ARN B. GELLANGARIN GENERAL MANAGER	CONTENT: AS SHOWN
				DRAWN: RRA CHECKED: MGG REVISION: 01 DATE: April 2010

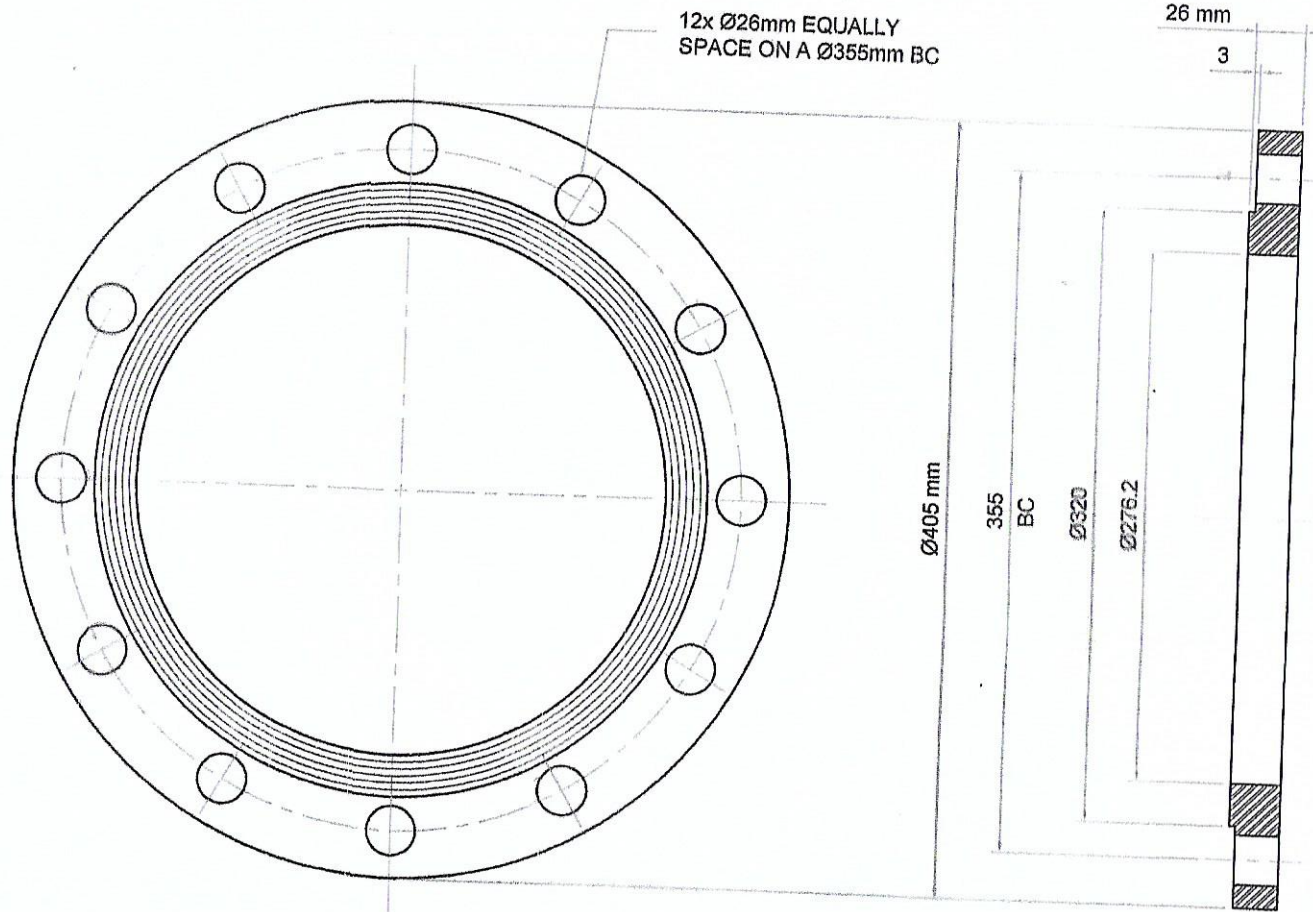

PLAN

SECTION

GSC WATER DISTRICT
 ENGINEERING & CONSTRUCTION DEPT.
 E. FERNANDEZ ST., LAGAO, GSC
 TEL. NO. 301 - 3835

MATERIALS DESCRIPTION: 200 SHOP DRAWING OF - 200mmØ STEEL FLANGE (10"/DN250)	PREPARED BY: REY R. ANORA ENGINEERING AIDE	CHECKED BY: ENGR. MICHEL G. GABALES MANAGER A - PDD	RECOMMENDING APPROVAL: ENGR. ROGELIO A. BESANA, JR. MANAGER A - ECD	APPROVED BY: ENGR. ARN B. GELLANGARIN GENERAL MANAGER	CONTENT: AS SHOWN
			DRAWN: RRA CHECKED:	REVISION: DATE: June 2017	SHEET NO. 51