



Republic of the Philippines
GENERAL SANTOS CITY WATER DISTRICT
E. Fernandez Street, Barangay Lagao General Santos
Telephone No.: 552-3824; Telefax No.: 553-4960
Email Address: gscwdprocurement@yahoo.com

GPM-014-3

REQUEST FOR QUOTATION

RFQ #: 3-0223-009 DATE: 02/09/2023

SUPPLIER: _____
ADDRESS: _____
TELEPHONE NO. : _____
TIN NO. : _____

Dear Sir/Madam,

Pls. quote your lowest price on the item/s listed below subject to general condition stating the shortest time of delivery and submit your quotation duly signed by your representative not later than 02/15/2023, Pls. furnish this office the following articles subject to the terms and conditions contained therein.

ITEM NO.	DESCRIPTION	QTY.	UNIT	UNIT PRICE
1	STEEL FLANGE 150MM : FABRTICATION; PLEASE SEE ATTACHED SHOP DRAWING-ABC: PHP 100,000.00	20	pcs.	P
2	STEEL FLANGE 200MM : FABRTICATION; PLEASE SEE ATTACHED SHOP DRAWING-ABC: PHP 130,000.00 ##### nothing follows #####	20	pcs.	P

Delivery term: _____
Price Validity : _____
Terms of Payment: _____

Place of Delivery: GSCWD Bodega
****No partial delivery allowed****
Note: 6% WITHHOLDING TAX DEDUCTION
PR NO.: 0123-088

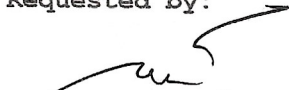
Requested by: _____

GERSON R. CABANERO
MATERIAL PROCUREMENT
OFFICER A

Price quoted by: _____

Supplier

Date

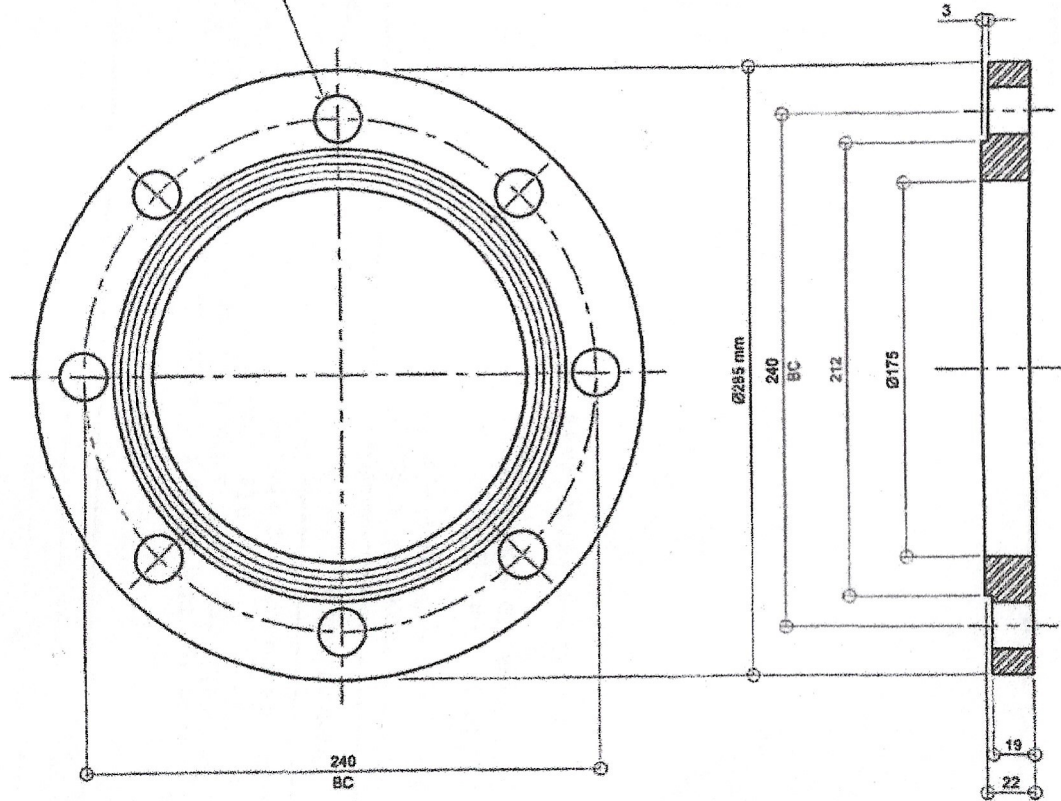
6 x Ø22mm EQUALLY SPACE ON A Ø240mm BC



PLAN

SECTION

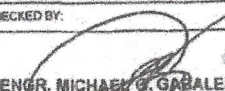
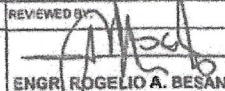
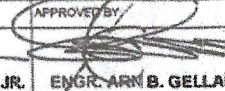
 GENERAL SANTOS CITY WATER DISTRICT ENGINEERING & CONSTRUCTION DEPARTMENT PLANNING AND DESIGN DIVISION 8, FERRAZ STREET, BRYAN LARAO, ECL, SANTOS CITY TEL. NO.: (0972) 632 - 3024	DESCRIPTION:	CHECKED BY:	REVIEWED BY:	APPROVED BY:	CONTENT:	SHEET NO.:	
	SHOP DRAWING OF 150mm(6")Ø REVISED STEEL FLANGE	 ENGR. MICHAEL G. GABALES MANAGER/ PDD	 ENGR. ROGELIO A. BESANA, JR. MANAGER A - ECD	 ENGR. ARN B. GELLANGARIN GENERAL MANAGER	AS SHOWN DRAWN: RRA CHECKED: MGG	REVISION: 01 DATE: April 2019	1 1

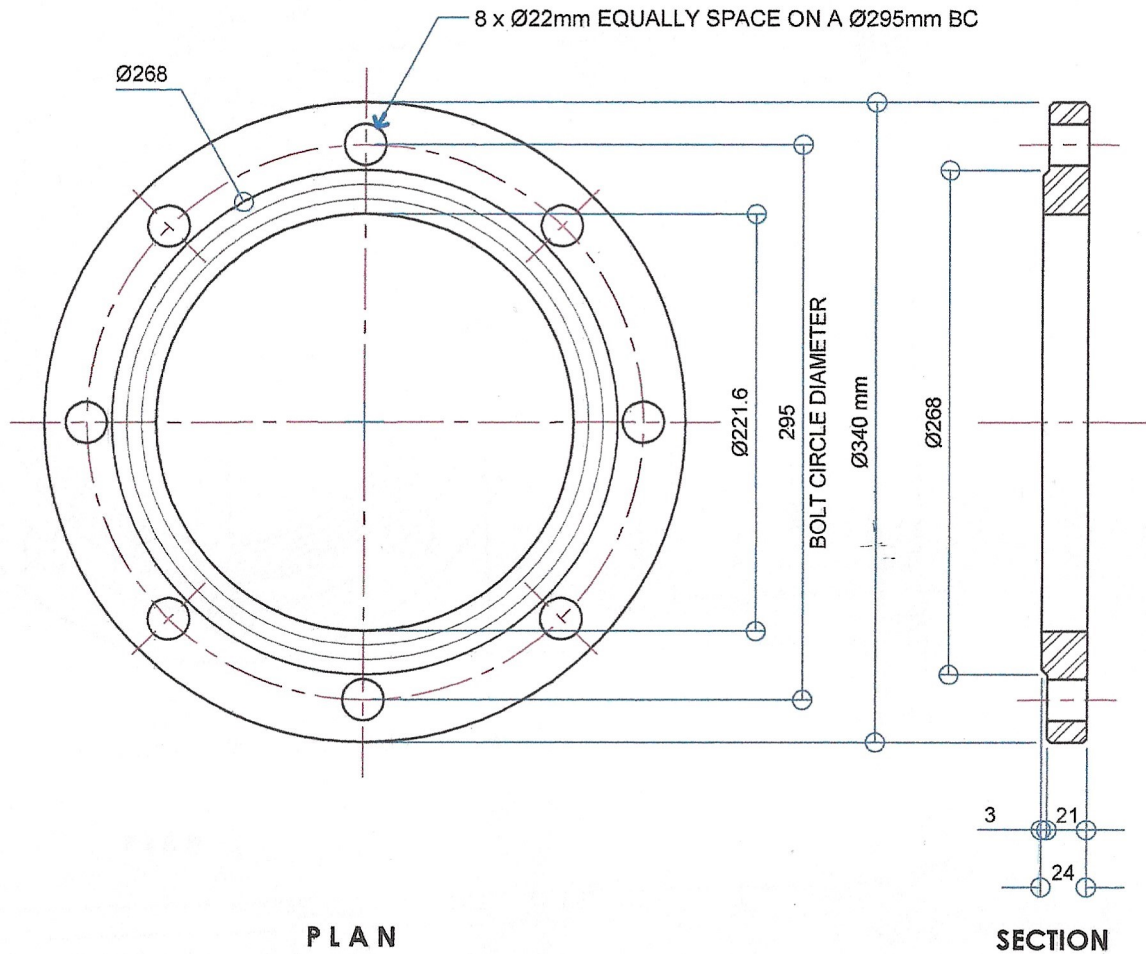

SANTOS CITY WATER DISTRICT MUNICIPAL STREET, BRGY. LAGAO, GEN. SANTOS CITY PLANNING AND DESIGN DIVISION TEL. NO.: (093) 552 - 3824	MATERIALS DESCRIPTION:	PREPARED BY:	RECOMMENDING APPROVAL:	APPROVED BY:	CONTENT:	SHEET NO.:
	SHOP DRAWING OF 200mmØ STEEL FLANGE	 REY R. ANORA SENIOR DRAFTSMAN	 ENGR. M.A. CELIA N. DANDAN OIC - PDD	 ENGR. ROGELO A. BESANA, JR. AGM - Operation and Technical Services	AS SHOWN	
		DRAWN: RRA	REVISION:	CHECKED:	DATE: 02/07/2023	