



Republic of the Philippines  
GENERAL SANTOS CITY WATER DISTRICT  
E. Fernandez Street, Barangay Lagao General Santos  
Telephone No.: 552-3824; Telefax No.: 553-4960  
Email Address: gscwdprocurement@yahoo.com

GPM-014-2

### REQUEST FOR QUOTATION

RFQ #: 3-0522-026      DATE: 7/7/2022

SUPPLIER: \_\_\_\_\_  
ADDRESS: \_\_\_\_\_  
TELEPHONE NO. : \_\_\_\_\_  
TIN NO. : \_\_\_\_\_

Dear Sir/Madam,

Pls. quote your lowest price on the item/s listed below subject to general condition stating the shortest time of delivery and submit your quotation duly signed by your representative not later than 7/13/2022, Pls. furnish this office the following articles subject to the terms and conditions contained therein.

ITEM NO.	DESCRIPTION	QTY.	UNIT	UNIT PRICE
1	D.I. SWING CHECK VALVE 200MM(8``) : 10 YEARS WARRANTY-ABC: PHP 120,000.00 (Please see attached Technical Specification) ##### nothing follows #####	2	<ignor P	

Date of Delivery: \_\_\_\_\_  
Price Validity : \_\_\_\_\_  
Terms of Payment: \_\_\_\_\_

Place of Delivery: GSCWD Bodega  
\*\*\*\*\*No partial delivery allowed\*\*\*\*  
Note: 6% WITHHOLDING TAX DEDUCTION  
PR NO.: 0522-006

Requested by:

Price quoted by:

\_\_\_\_\_  
Supplier

\_\_\_\_\_  
Date

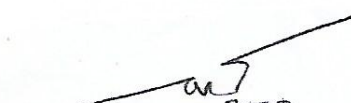
  
**GESEM R. CABAÑERO**  
MATERIAL PROCUREMENT  
OFFICER A



## TECHNICAL SPECIFICATION

### TITLE: PURCHASE OF BRAND-NEW DI SWING CHECK VALVE

#### 1.0 SCOPE OF CONTRACT

The scope shall be supply and delivery of Two (2) set brand new DI Swing Check Valve to General Santos City Water District (GSCWD).

Particulars	Requirements
Size mm (inches)	200 (8)
Body	Ductile Iron
Shaft	Stainless Steel
Gasket	EPDM Rubber
Bolt, Washer , Pin	Stainless Steel
Metal Seated Disc	EPDM Rubber with Steel Insert
Seat Ring	Dezincification Resistant Brass
Lever	Steel
Bore	Full Bore
Working Temperature	70°C
Pressure Nominale	PN16
Flange No. of Holes	12

#### 2.0 DRAWING

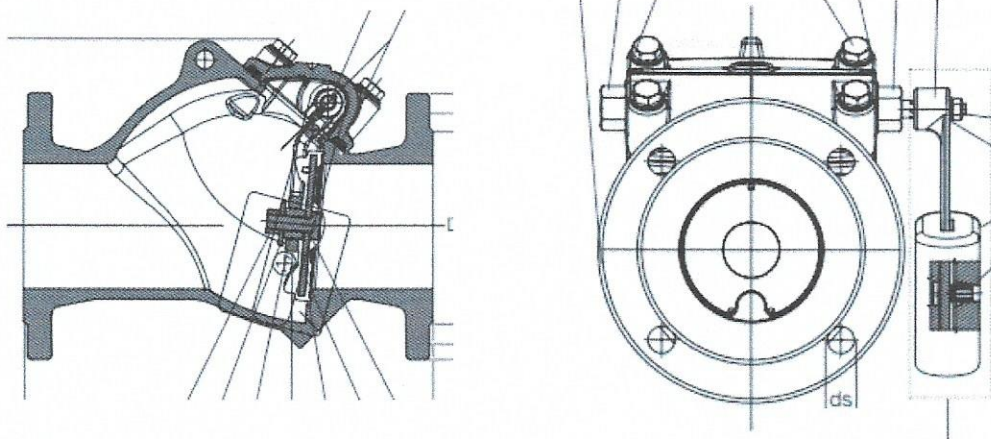





### 3.0 DIMENSIONS

DN	Flange	L	H	W	Theoretical
mm	drilling	mm	mm	mm	Weight/kg
200	PN16	495	230	340	67

### 4.0 STANDARDS

- Should be designed to EN 1074-3
- Face-to-face dimension according to EN 558
- Flange drilling according to EN 1092-1

### 5.0 TERMS AND CONDITIONS

- The scope of work shall be supply and delivery **Two (2) sets brand new DI Swing Check Valve** to General Santos City Water District (GSCWD).
- All bidder is required to submit and include documents but not limited to **manuals, data sheets, and Manufacturers Authorization Certificate specific to this project** in there bidding documents.
- The winning bidder shall deliver the two (2) sets **brand new DI Swing Check Valve**, within **Ninety (90)** calendar days upon receipt of Purchase Order (PO).
- The winning bidder shall be subjected to Liquidated Damages (LD) for each day of delay as provided by the IRR of RA 9184.
- That the winning bidder shall issue a warranty certificate of at least ten (10) years and the warranty shall commence from the date of commissioning of the pumping equipment. That the bidder must have an available qualified and trained technicians 24/7 in case of equipment failure.



Republic of the Philippines  
GENERAL SANTOS CITY WATER DISTRICT (GSCWD)  
GSCWD Bldg., E. Fernandez Street (Emergency Road), Lagao, General Santos City  
Telephone No.: 552-3824/554-7231; Telefax No.: 553-4960  
E-mail Address: gscwaterdistrict@yahoo.com

---

Prepared by:

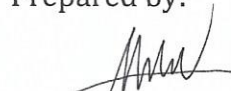
  
**MA. CELIA N. DANDAN, CE**  
TWG - Member

  
**JUDY A. LIM-PASMAN, JD**  
TWG - Member

  
**MICHAEL G. GABALES, REE**  
TWG - HEAD

Recommending Approval:

  
**ROGELIO A. BESANA JR. C.E., RMP**  
Assistant General Manager - Operations and Technical Services

Approval:

  
**ARN B. GELLANGARIN, PME**  
General Manager A